

FULL LOAD AMPS	
FAN MOTOR	460 / 3 / 60
5 HP, 1140 RPM	8.8
5 HP, 875 RPM	9.5
3 HP, 875 RPM	6.1

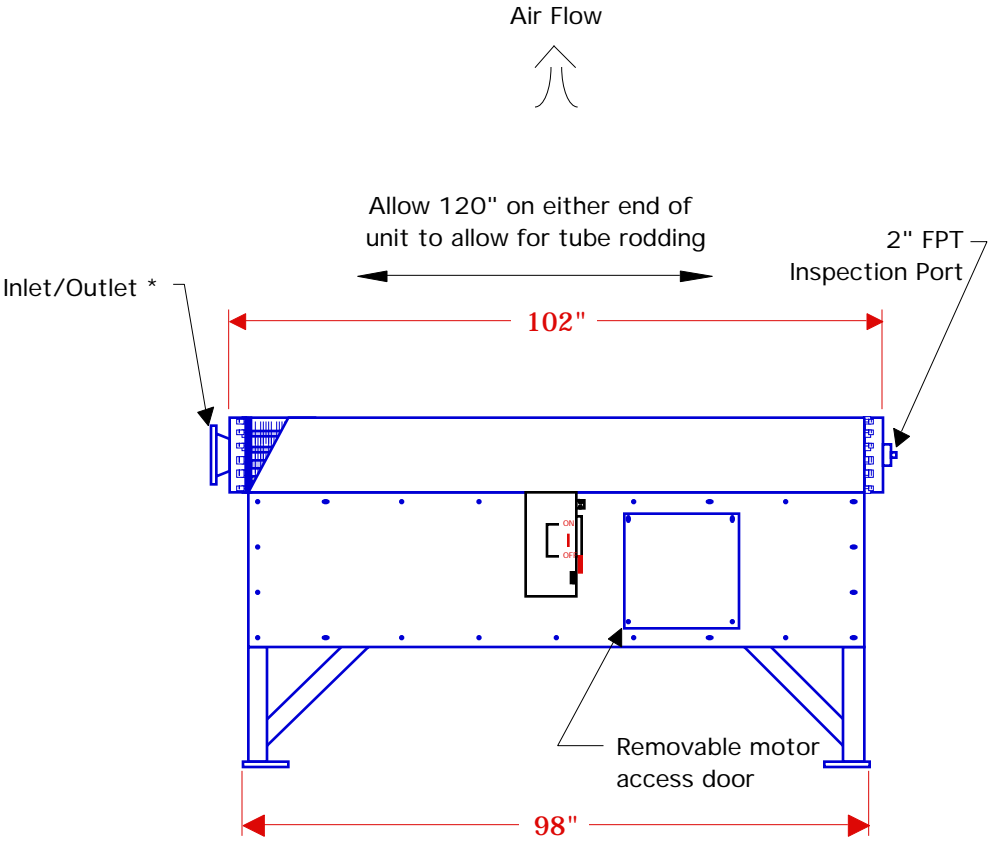
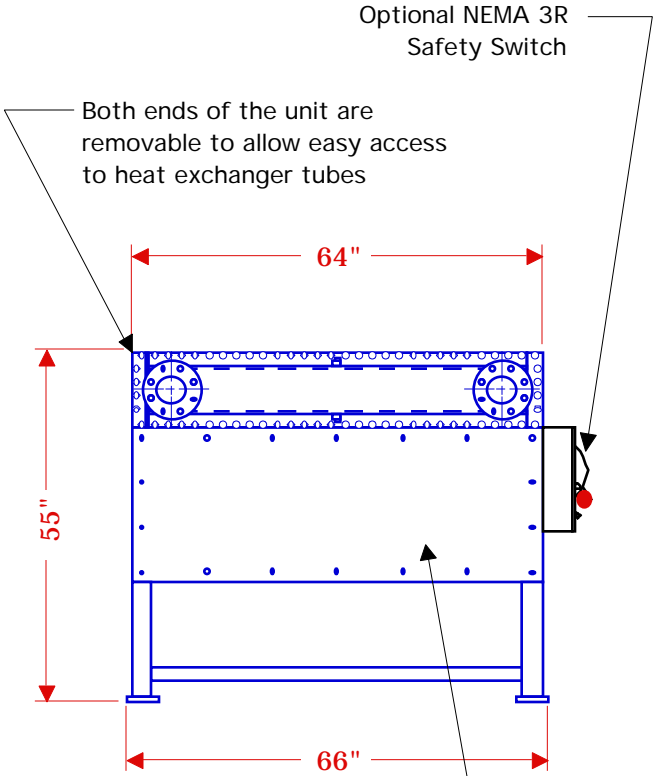

Heavy gage galvanized steel plenum insures years of corrosion free operation.

\* Either nozzle may be the inlet or outlet

Note: All dimensions are approximate and are subject to change without notice.

Weight: 2632 lbs

	<b>SBS CORPORATION</b> 81 MILL STREET • ROCHESTER, MI 48307 • USA		
	U.S. & Canada 1-800-662-8776 • Fax 1-248-652-4303 • www.sbcorporation.com		
CUSTOMER:			
DRAWN BY: GSB	DATE: 11/16/01	SCALE: 1 : 30	
<h2>Quench Air Model 5084</h2>			