

FULL LOAD AMPS	
FAN MOTOR	460 / 3 / 60
5 HP, 1140 RPM	8.4
5 HP, 875 RPM	9.5
3 HP, 875 RPM	6.8

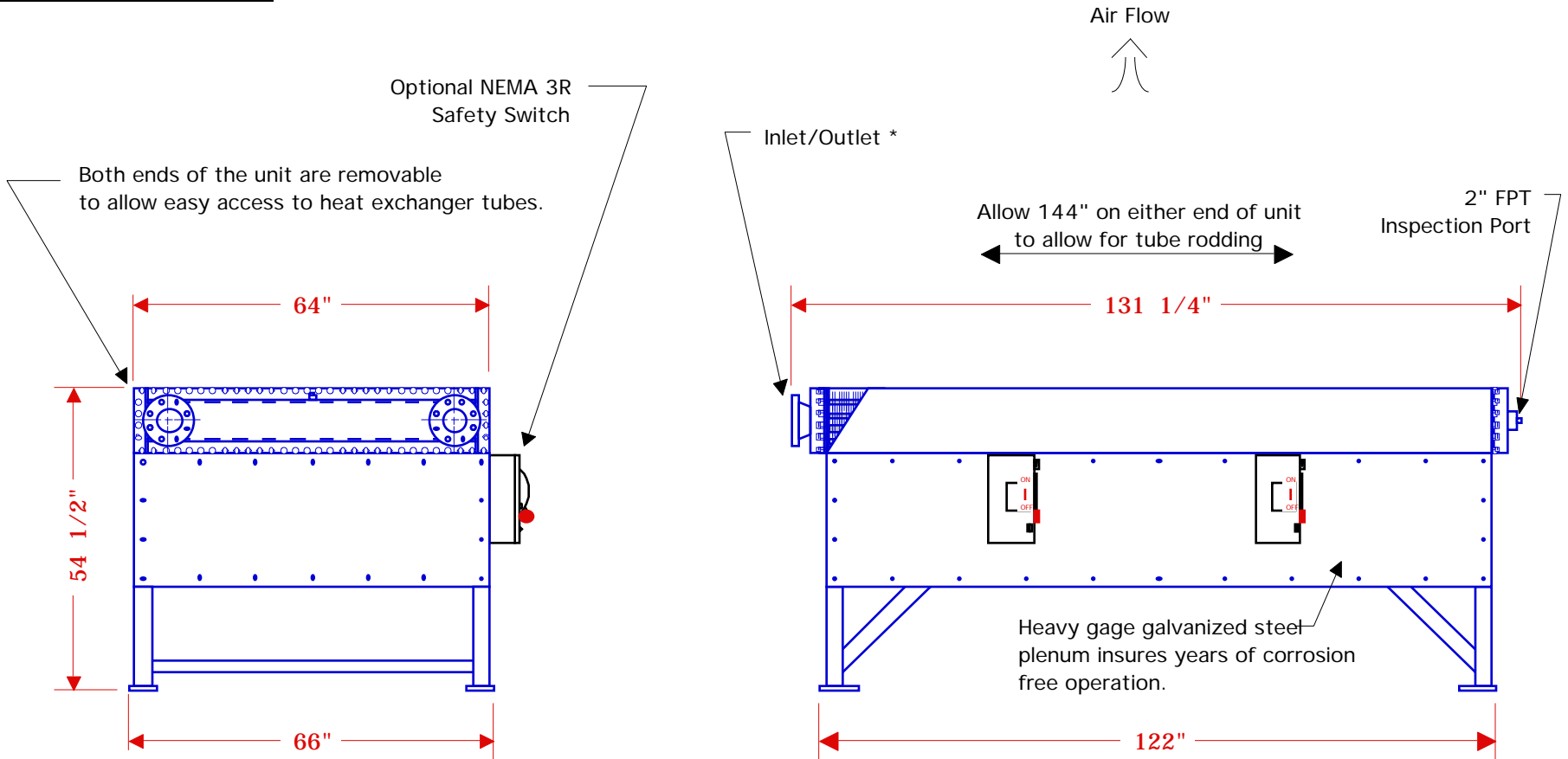

* Either nozzle may be the inlet or outlet
 Note: All dimensions are approximate and are subject to change without notice.

Weight: 3309 lbs

SBS		SBS CORPORATION	
81 MILL STREET • ROCHESTER, MI 48307 • USA			
U.S. & Canada 1-800-662-8776 • Fax 1-248-652-4303 • www.sbcorporation.com			
CUSTOMER:			
DRAWN BY:	GSB	DATE:	10/31/01
		SCALE:	1 : 30
Quench Air Model 5104			