

FULL LOAD AMPS	
FAN MOTOR	460 / 3 / 60
5 HP, 1140 RPM	8.8
5 HP, 850 RPM	9.5
3 HP, 860 RPM	6.1

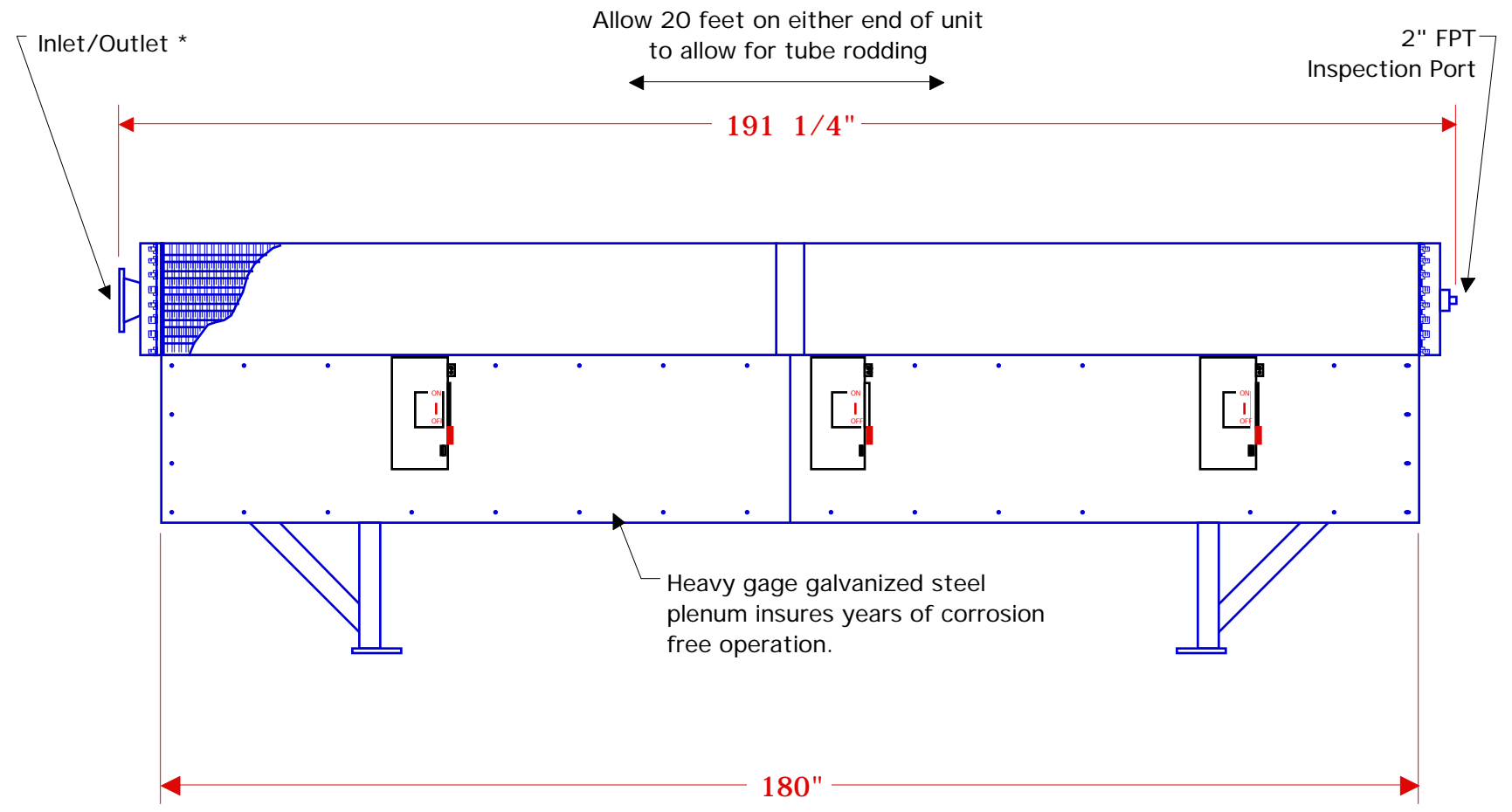
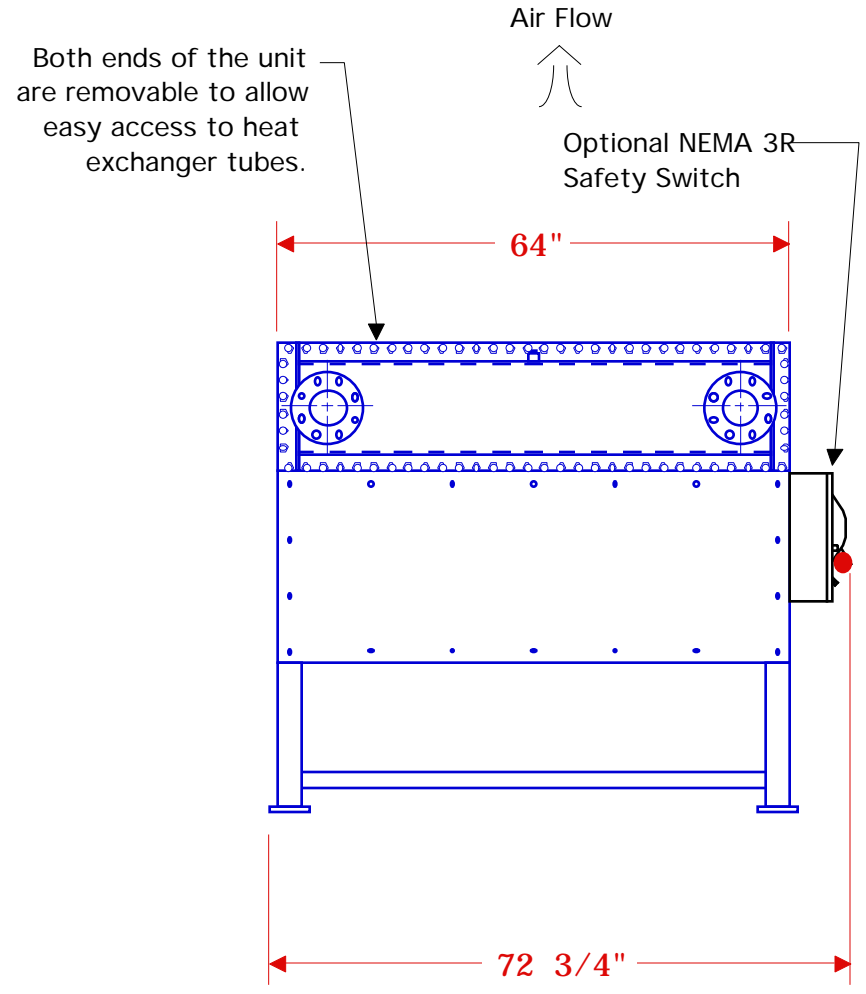
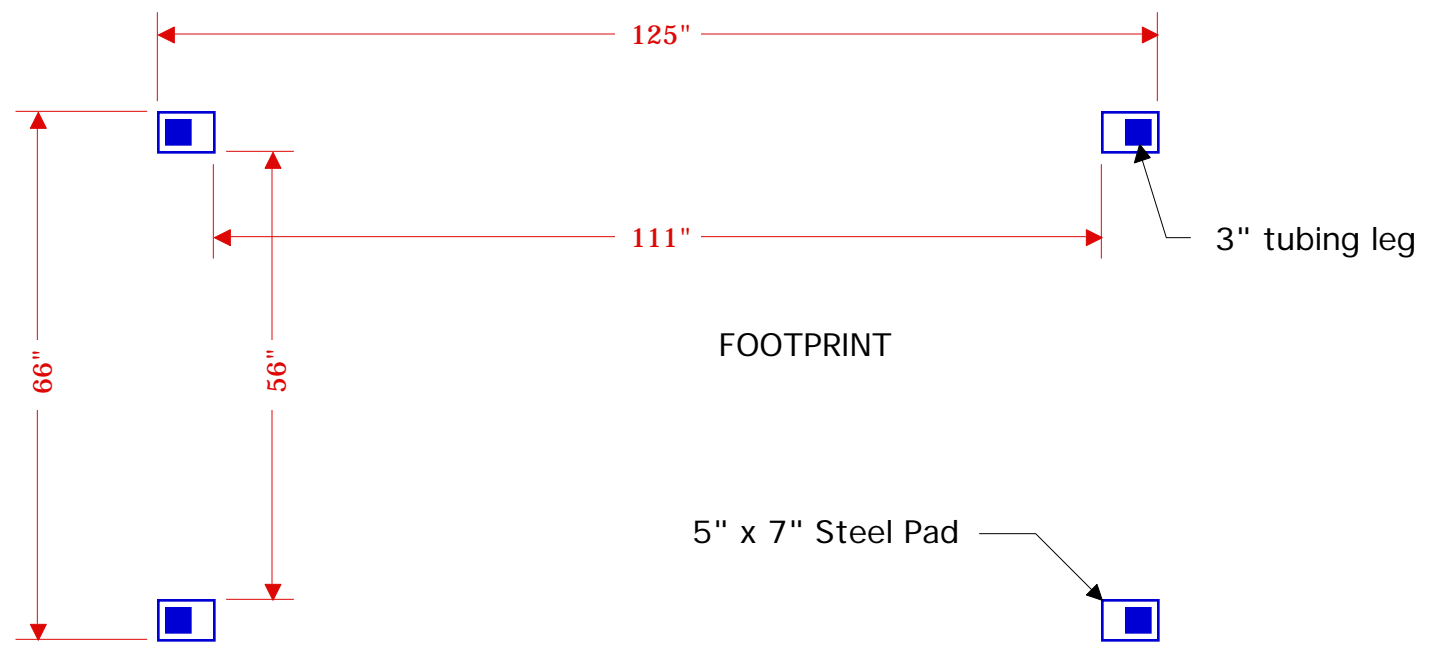

* NOTE: Either Nozzle may be the inlet or outlet
 All dimensions are approximate and subject to change without notice.

Weight: 5760 lbs

SBS CORPORATION 81 MILL STREET • ROCHESTER, MI 48307 • USA U.S. & Canada 1-800-662-8776 • Fax 1-248-652-4303 • www.sbcorporatc		
CUSTOMER:		
DRAWN BY: GSB	DATE: 1/17/01	SCALE: 1 : 24
Quench Air Model 5156		