

FULL LOAD AMPS	
FAN MOTOR	460 / 3 / 60
5 HP, 1140 RPM	8.8
5 HP, 850 RPM	9.5
3 HP, 860 RPM	6.1

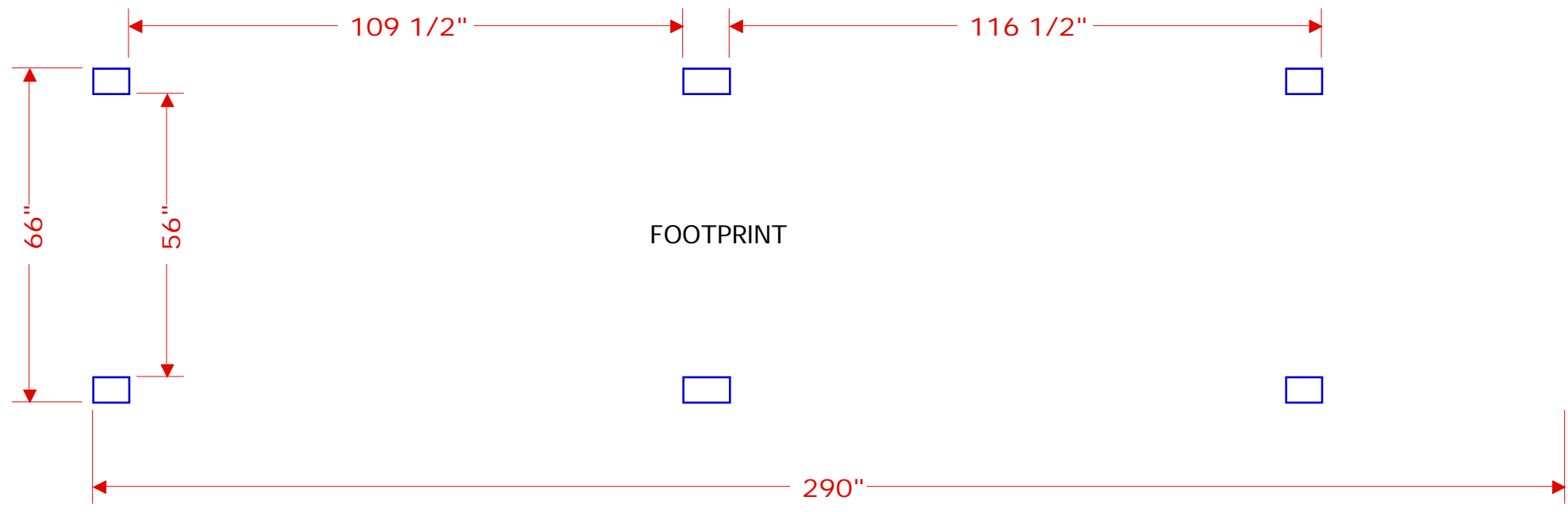

Both ends of the unit are removable to allow easy access to heat exchanger tubes.

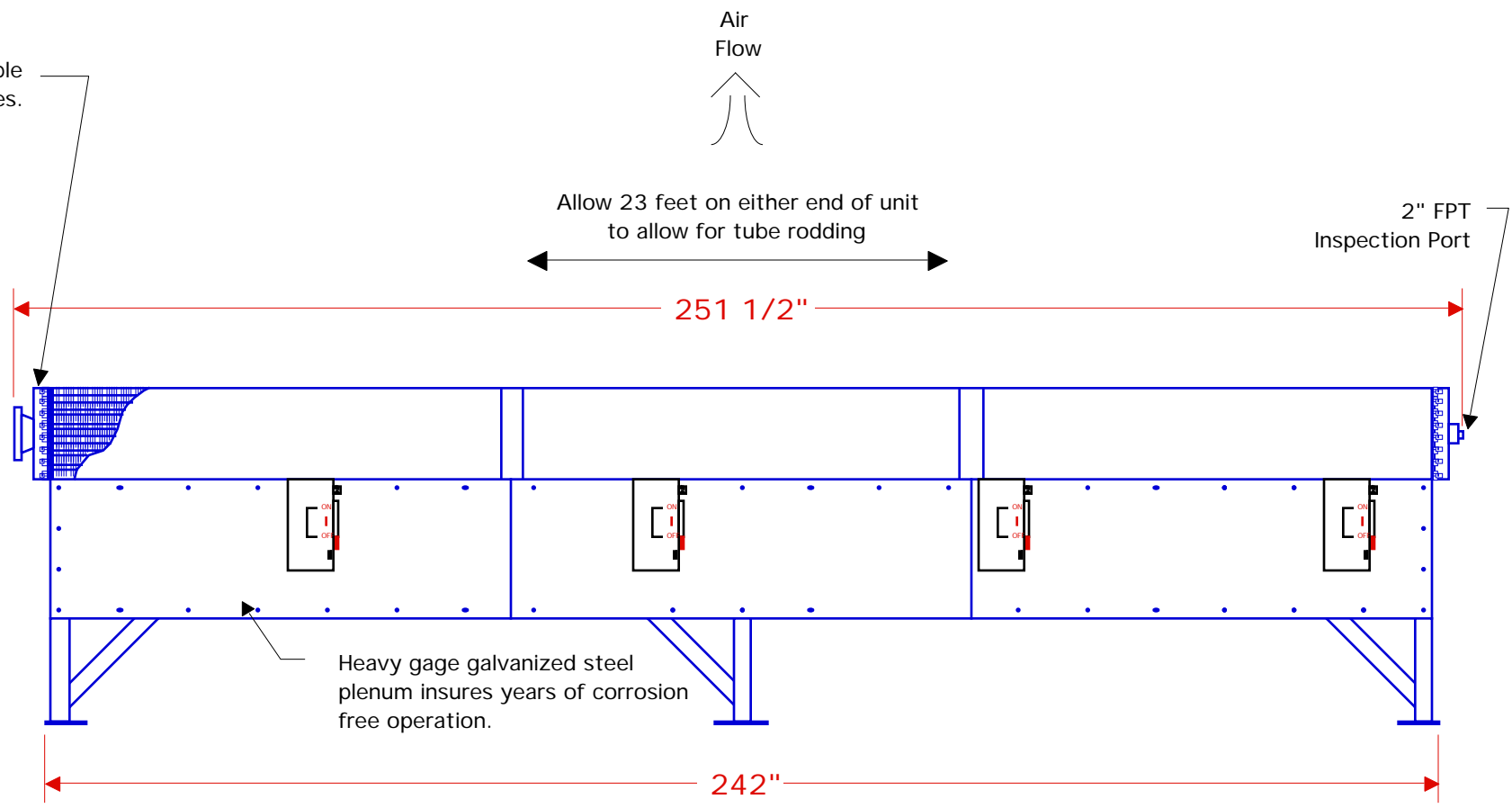
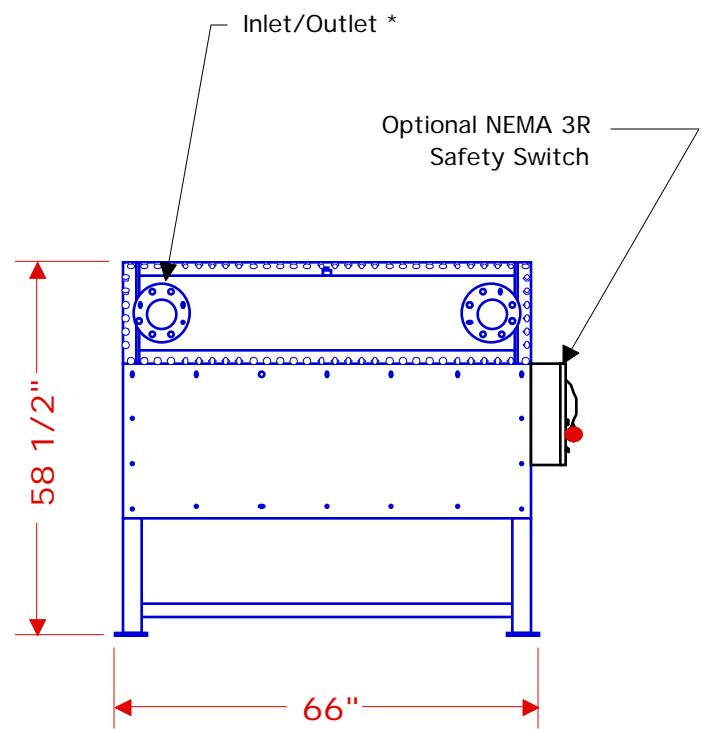

Heavy gage galvanized steel plenum insures years of corrosion free operation.

* Either nozzle may be the inlet or outlet
 Nozzle locations will vary with application. Consult SBS for certified locations.
 NOTE: All dimensions are +/- 1/2" unless noted
 Weight: 8307 lbs

SBS	SBS CORPORATION		
	81 MILL STREET • ROCHESTER, MI 48307 • USA		
U.S. & Canada 1-800-662-8776 • Fax 1-248-652-4303 • www.sbscorporation.com			
CUSTOMER:			
DRAWN BY: GSB	DATE: 11/29/01	SCALE: 1 : 30	
Quench Air Model 5206			