

*** STANDARD FEATURES ***

- Removes separable solids larger than 50 micron (325 mesh) and 20% heavier than liquid
- Accommodates flow rates from 59 to 110 US GPM.
- 150 PSI working pressure
- Carbon steel construction
- Fully pressure tested

*** AVAILABLE OPTIONS ***

- 150# Flanged Inlet & Outlet
- Bracket Mounting
- Foot Mounting
- Inlet/Outlet Pressure Gauges
- Removable Dome for easy clean out
- Automatic purge valve with timer
- ASME certified for 150 PSIG @ 225°F
- 304, 316 Stainless Steel construction

*** PRESSURE DROP ***

To determine pressure drop (PSI) at known flow rates, use the following formula:

$$\Delta P = \left(\frac{\text{GPM}}{34} \right)^2$$

Note - All dimensions are approximate and are subject to change without notice.

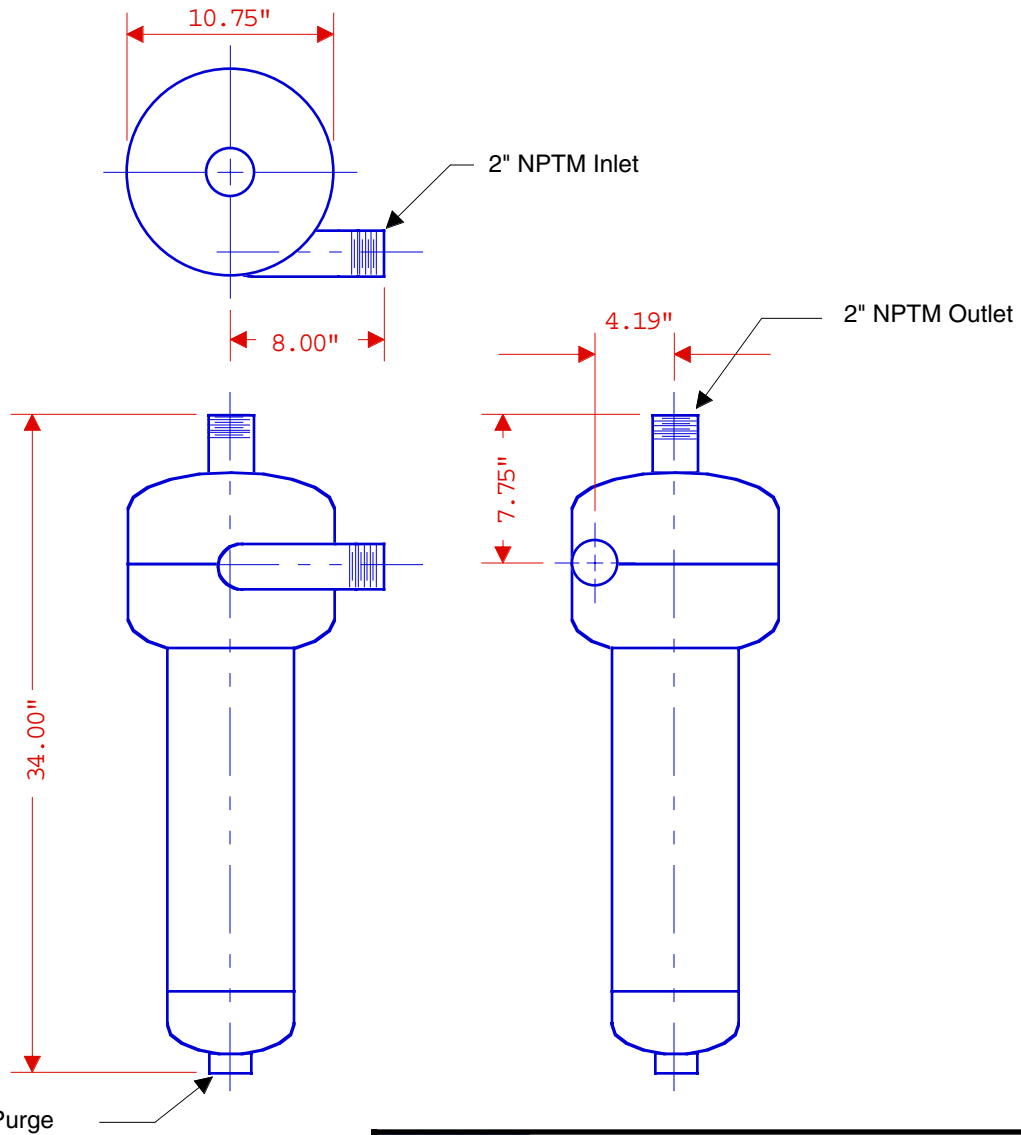

1-1/2" FPT Purge

Net Weight: 68 lbs
 Weight (full): 113 lbs
 Volume: 5.5 gals

 SBS CORPORATION 81 MILL STREET • ROCHESTER, MI 48307 • USA		
U.S. & Canada 1-800-662-8776 • Fax 1-248-652-4303 • www.sbcorporation.com		
CUSTOMER:		
DRAWN BY: GSB	DATE: 12/14/01	SCALE: 1 : 10
CS-200 Centrifugal Separator		