

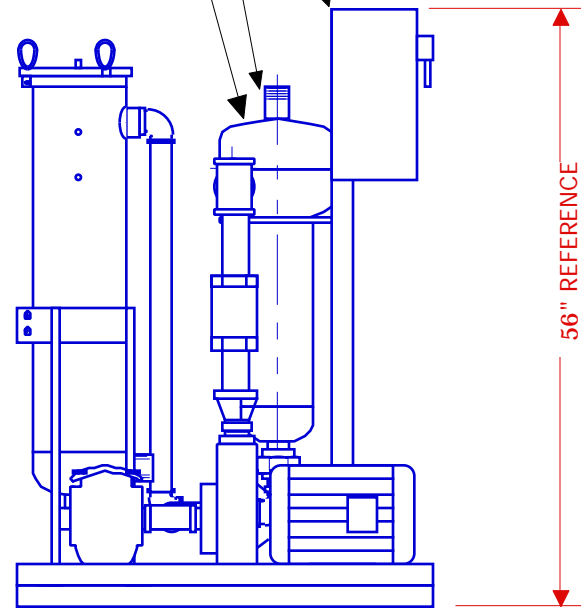
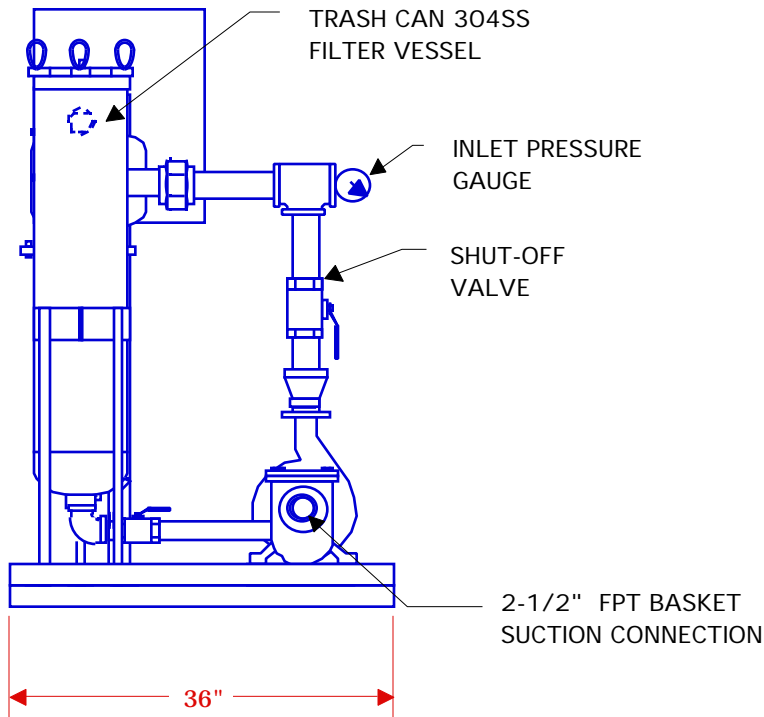

CIRCULATING PUMP
3 HP, 3500 RPM MOTOR
150 GPM @ 55' TDH

SBS CENTRIFUGAL SEPARATOR
MODEL CS-250

NEMA 4 CONTROL PANEL
460-3-60
SINGLE POINT FIELD CONNECTION

2-1/2" MPT WATER DISCHARGE



| | | |
|--|--------------|---------------|
|  SBS CORPORATION 81 MILL STREET • ROCHESTER, MI 48307 • USA | | |
| U.S. & Canada 1-800-662-8776 • Fax 1-248-652-4303 • www.sbscorporation.com | | |
| CUSTOMER: | | |
| DRAWN BY: GSB | DATE: 8/5/03 | SCALE: 1 : 10 |

SBS Model TSP-250-TC Tower Scour Water Filter