

SBS CENTRIFUGAL SEPARATOR
MODEL CS-300F

INLET PRESSURE
GAUGE

ELECTRIC
PURGE VALVE

SHUT-OFF
VALVE

1 1/2" FNPT PIPE
TO SEWER

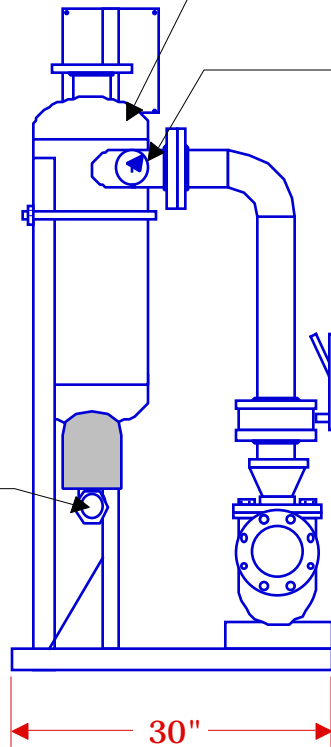

3" 150# WATER DISCHARGE

NEMA 4 CONTROL PANEL

CIRCULATING PUMP
200 GPM @ 80' TDH

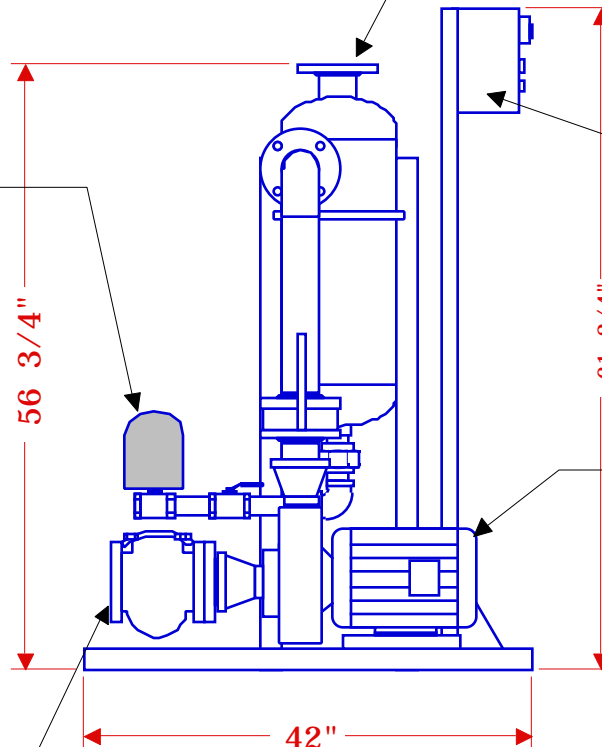

3" 125# SUCTION



SBS CORPORATION

81 MILL STREET • ROCHESTER, MI 48307 • USA

U.S. & Canada 1-800-662-8776 • Fax 1-248-652-4303 • www.sbscorporation.com

CUSTOMER:

DRAWN BY: GSB

DATE: 10/7/03

SCALE: 1 : 10

Model TSP-300F Tower Scour Package